

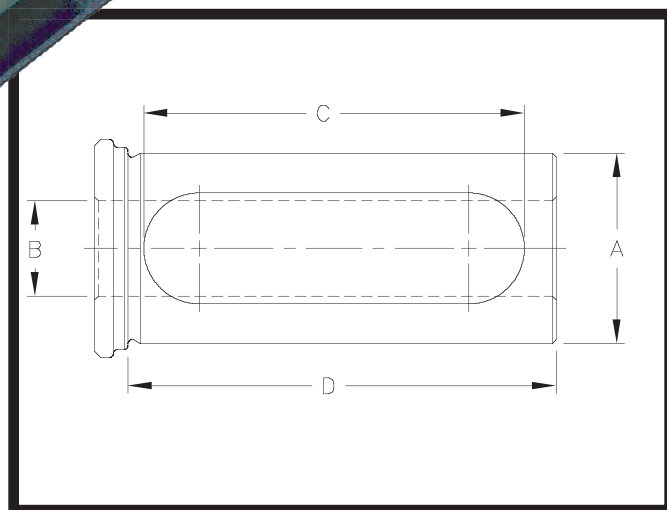

Toolholder Bushing Type “C”

This CNC Type C Bushing is designed for universal use on all C/N/C turning machines. To adapt a wide variety of Boring Bars, Drills, Reamers and Shank type tools. Precision machine hardened and ground concentric; made in the U.S.A. – BUILT TO LAST! Select the O.D. size that fits your machine and order from the chart below.

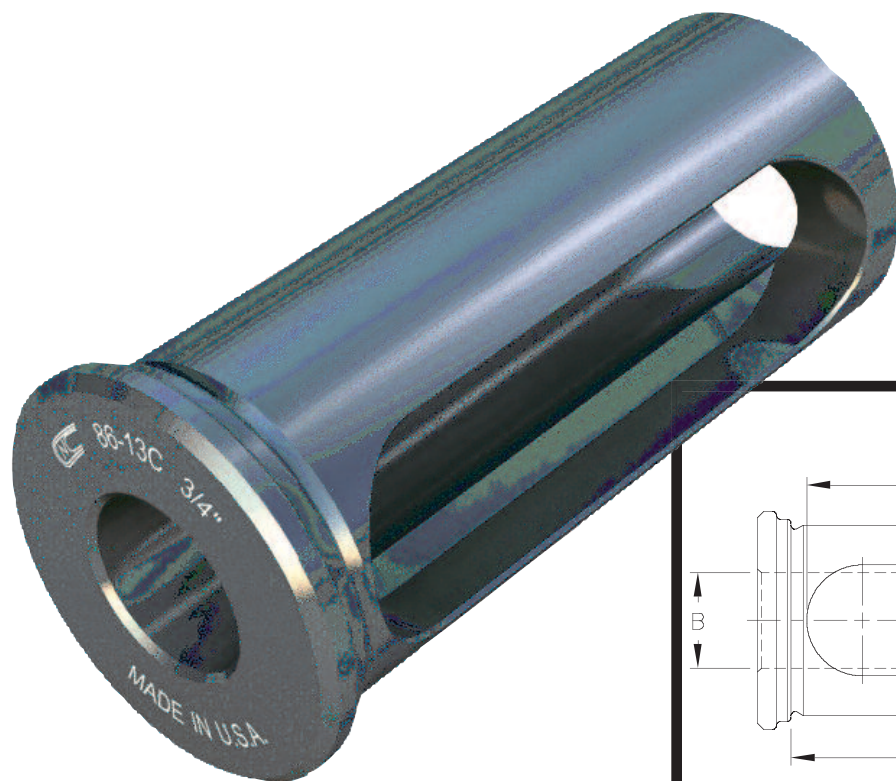

CNC PART NUMBER	BUSH DIA.		STANDARD BORE SIZES STOCKED		LENGTH OF SLOT C	LENGTH UNDER HEAD D	NUMBER OF SLOTS
	A		B				
	INCH	MM	INCH	MM			
CNC 86-10C	3/4	20	1/4, 5/16, 3/8, 1/2	6, 8, 10, 12	1 1/2	2	1
CNC 86-11C	1	25	1/4, 5/16, 3/8, 1/2, 5/8, 3/4	8, 10, 12, 16, 20	2 3/8	2 3/4	1
CNC 86-12C	1 1/4	32	3/8, 1/2, 5/8, 3/4, 7/8, 1	10, 12, 16, 20, 25	2 3/4	3 1/4	1
CNC 86-13C	1 1/2	40	3/8, 1/2, 5/8, 3/4, 7/8, 1, 1 1/4	10, 12, 16, 20, 25, 32	3	3 3/8	1
CNC 86-14C	1 3/4	45	1/2, 5/8, 3/4, 7/8, 1, 1 1/4, 1 1/2	12, 16, 20, 25, 32, 40	3 1/8	3 1/2	1
CNC 86-15C	2	50	1/2, 5/8, 3/4, 1, 1 1/4, 1 1/2, 1 3/4	12, 16, 20, 25, 32, 40, 45	3 5/8	4	1
CNC 86-16C	2 1/2	65	3/4, 1, 1 1/4, 1 1/2, 1 3/4, 2, 2 1/4	20, 25, 32, 40, 45, 50	4 1/8	4 1/2	1 or 2*
CNC 86-17C	3	80	1, 1 1/4, 1 1/2, 1 3/4, 2, 2 1/4, 2 1/2	25, 32, 40, 45, 50, 60, 65	4 5/8	5	1 or 2*
CNC 86-18C	3 1/2	90	1, 1 1/4, 1 1/2, 1 3/4, 2, 2 1/4, 2 1/2, 3	25, 32, 40, 45, 50, 60, 65	5	5 3/4	1 or 2*

*Special sizes available to fit your machine specifications: inch-metric, metric-inch, or metric-metric.

*Bushings 2 1/2 OD and larger: ID's larger than 1 1/2" have 2 slots.

*All Orders ship standard in inch sizes. If required; please specify metric O.D. or I.D. when ordering.